

TB 9-5855-1890-35

CHANGE 2

DEPARTMENT OF THE ARMY TECHNICAL BULLETIN

CALIBRATION PROCEDURE FOR THERMAL COLLIMATOR, SM-D-805691 (P/O AN/TAM-3 AND AN/TAM-3A) AND INFRARED COLLIMATOR, SM-D-969722

Headquarters, Department of the Army, Washington, DC
5 May 2003

Approved for public release; distribution is unlimited.

TB 9-5855-1890-35, 14 May 1991, is changed as follows:

1. Remove old pages and insert new pages as indicated below. New or changed material is indicated by a vertical bar in the margin of the page.

Remove Pages

1 and 2
7 and 8

Insert Pages

1 and 2
7 and 8

2. File this change sheet in front of the publication for reference purposes.

By Order of the Secretary of the Army:

ERIC K. SHINSEKI
General, United States Army
Chief of Staff

OFFICIAL:

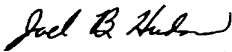
JOEL B. HUDSON
Administrative Assistant to the
Secretary of the Army

0306901

Distribution:

To be distributed in accordance with IDN 342084, requirements for calibration procedure TB 9-5855-1890-35.

TB 9-5855-1890-35

CHANGE 1

DEPARTMENT OF THE ARMY TECHNICAL BULLETIN

CALIBRATION PROCEDURE FOR THERMAL COLLIMATOR, SM-D-805691 (P/O AN/TAM-3 AND AN/TAM-3A) AND INFRARED COLLIMATOR, SM-D-969722

Headquarters, Department of the Army, Washington, DC
11 September 2001

Approved for public release; distribution is unlimited.

TB 9-5855-1890-35, 14 May 1991, is changed as follows:

1. Remove old pages and insert new pages as indicated below. New or changed material is indicated by a vertical bar in the margin of the page.

Remove Pages

1 and 2
7 and 8

Insert Pages

1 and 2
7 and 8

2. File this change sheet in front of the publication for reference purposes.

By Order of the Secretary of the Army:

ERIC K. SHINSEKI
General, United States Army
Chief of Staff

OFFICIAL:

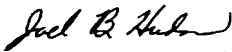
JOEL B. HUDSON
Administrative Assistant to the
Secretary of the Army

0121911

Distribution:

To be distributed in accordance with IDN 342084, requirements for calibration procedure TB 9-5855-1890-35.

U.S. GOVERNMENT PRINTING OFFICE: 2001 733-116/40210

***TB 9-5855-1890-35**

SUPERSEDED COPY DATED 21 NOVEMBER 1988

DEPARTMENT OF THE ARMY TECHNICAL BULLETIN

CALIBRATION PROCEDURE FOR THERMAL COLLIMATOR, SM-D-805691 (P/O AN/TAM-3 AND AN/TAM-3A) AND INFRARED COLLIMATOR, SM-D-969722

Headquarters, Department of the Army, Washington, DC

14 May 1991

Approved for public release; distribution is unlimited

REPORTING OF ERRORS AND RECOMMENDING IMPROVEMENTS

You can help improve this publication. If you find any mistakes or if you know of a way to improve the procedure, please let us know. Mail your letter or DA Form 2028 to: Commander, U. S. Army Aviation and Missile Command, ATTN: AMSAM-MMC-MA-NP, Redstone Arsenal, AL 35898-5230. A reply will be furnished to you. You may also send in your comments electronically to our e-mail address: 2028@redstone.army.mil, or FAX 256-842-6546/DSN 788-6546

		Paragraph	Page
SECTION	1.	IDENTIFICATION AND DESCRIPTION	
		Test instrument identification	1 2
		Forms, records, and reports.....	2 2
		Calibration description	3 2
	II.	EQUIPMENT REQUIREMENTS	
		Equipment required	4 2
		Accessories required	5 3
	III.	CALIBRATION PROCESS	
		Preliminary instructions	6 3
		Equipment setup.....	7 4
		Calibration	8 7
		Final procedure.....	9 8

*This bulletin supersedes TB 9-5855-1890-35, 21 November 1988, including all changes.

**SECTION I
IDENTIFICATION AND DESCRIPTION**

1. Test Instrument Identification. This bulletin provides instructions for the calibration of Thermal Collimator, SM-D-805691 (p/o AN/TAM-3 and AN/TAM-3A) and Infrared Collimator, SM-D-969722. TM 9-5855-255-14 was used as the prime data source in compiling these instructions. The equipment being calibrated will be referred to as the TI (test instrument) throughout this bulletin.

a. Model Variations. All models must have lights extinguished in bar target mode. Some models have a disabling switch; on other models the lights have been removed. If TI does not have a disabling switch and bar target is illuminated, corrective action must be taken by DS/GS unit.

b. Time and Technique. The time required for this calibration is approximately 4 hours, using the physical technique.

2. Forms, Records, and Reports

a. Forms, records, and reports required for calibration personnel at all levels are prescribed by TB 750-25.

b. Adjustments to be reported are designated (R) at the end of the sentence in which they appear. When adjustments are in tables, the (R) follows the designated adjustment. Report only those adjustments made and designated with (R).

3. Calibration Description. TI parameters and performance specifications which pertain to this calibration are listed in table 1.

Table 1. Calibration Description

Test instrument parameters	Performance specifications
Temperature differential	Temperature: 4.5 °C (ambient to heater) Deviation: ±0.45 °C

**SECTION II
EQUIPMENT REQUIREMENTS**

4. Equipment Required. Table 2 identifies the specific equipment to be used in this calibration procedure. This equipment is issued with Secondary Transfer Calibration Standards Set AN/GSM-286. Alternate items may be used by the calibrating activity when the equipment listed in table 2 is not available. The items selected must be verified to perform satisfactorily prior to use and must bear evidence of current calibration. The equipment must meet or exceed the minimum use specifications listed in table 2. The accuracies listed in table 2 provide a four-to-one ratio between the standard and TI.

5. Accessories Required. Common usage accessories not listed in this calibration procedure and peculiar accessories listed in table 3 are issued as indicated in paragraph 4 above.

Table 2. Minimum Specifications of Equipment Required

Common name	Minimum use specifications	Manufacturer and model (part number)
DIFFERENTIAL THERMOCOUPLE SET	Range: 0 to 5 °C differential Accuracy: ±0.11 °C	Omega Engineering 0.020 Type K (7917040) ¹
DIFFERENTIAL VOLTMETER	Range: 0 to 200 µV Accuracy: ±2 µV	John Fluke, Model 887AB/AN (887AB/AN)
DIGITAL VOLTMETER	Range: 0 to 6 V dc Accuracy: ±0.2%	Hewlett-Packard, Model 3490AOPT060 (3490AOPT060)

¹Part of calibration kit 7917034, limited deployed.

Table 3. Accessories Required

Common name	Description (part number)
ADAPTER ¹	Offset voltage pin (7917036) ²
COTTON TIP APPLICATOR ³	Swap with cotton tip on one end
HOLDING CLAMP ¹	Mounting post clamp (7917039) ²
LABORATORY CLAMP ¹	Laboratory clamp (MS-36012-1) ²
LEAD	42-in., single banana to test hook (red) (7917035-2) ²
LEAD	42-in., single banana to test hook (black) (7917035-1) ²
PASTE REMOVAL SOLVENT ³	WD40 or equivalent
THERMOCOUPLE MOUNTING POST ¹	Mounting post with base (7917037) ²
THERMALLY CONDUCTIVE PASTE ³	Omegatherm 201 or equivalent

¹Two required.

²Component part of calibration kit 7917034, limited deployed.

³Additional equipment required.

SECTION III CALIBRATION PROCESS

6. Preliminary Instructions

a. The instructions outlined in paragraphs **6** and **7** are preparatory to the calibration process. Personnel should become familiar with the entire bulletin before beginning the calibration.

b. Items of equipment used in this procedure are referenced within the text by common name as listed in tables 2 and 3.

c. Unless otherwise specified, verify the result of each test and, whenever the test requirement is not met, take corrective action before continuing with the calibration. Adjustments required to calibrate the TI are included in this procedure. Additional maintenance information is contained in TM 9-5855-255-14 for this TI.

d. Unless otherwise specified, all controls and control settings refer to the TI.

7. Equipment Setup

NOTE

HIGH VOLTAGE is used or exposed during the performance of this calibration. DEATH ON CONTACT may result if personnel fail to observe safety precautions. REDUCE OUTPUT(S) to minimum after each step within the performance check where applicable.

- a. Remove external cover and internal shroud from TI.
- b. Set target select knob (fig. 1) to BAR position

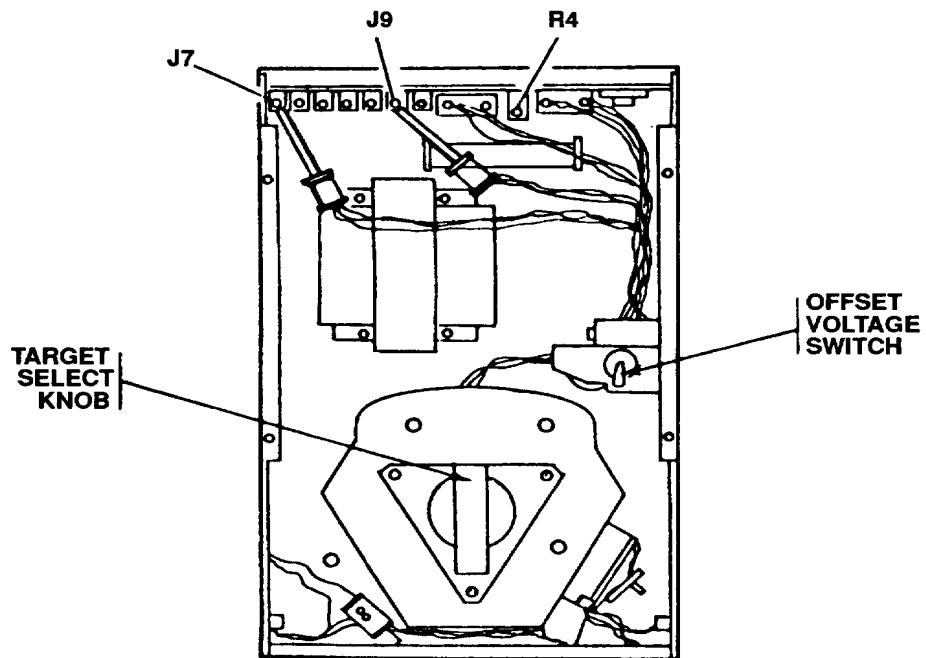

Figure 1. Temperature controller locations.

- c. Connect equipment as shown in figure 2 and as described in (1) and (2) below:
 - (1) Install thermocouple mounting post (pair) on base of TI (approximately center of second slot pair from exit port).
 - (2) Clamp differential thermocouple set (pair) in laboratory clamps and install on thermocouple mounting posts, using mounting post clamps.
- d. Using cotton tip applicator wood end, daub a small amount of thermally conductive paste on the extreme bottom of heater plate (fig. 3) on front of temperature controller.
- e. Place tip of thermocouple TC1 (fig. 3) against bottom of heater plate, in the thermally conductive paste.

- f.** Loosen mounting post clamp slightly.
- g.** Increase tension on thermocouple TC1 (fig. 3) to produce a moderate bow in thermocouple wire by sliding laboratory clamp forward (toward temperature controller) in mounting post clamp; then tighten mounting post clamp.
- h.** If necessary, physically position thermocouple TC1 on heater plate to the position shown in figure 3.
- i.** Daub a small amount of thermally conductive paste on side of brass housing of MRT target (fig. 3) housing (on temperature controller) and place tip of thermocouple TC2 (fig. 3) in the thermally conductive paste.
- j.** Repeat technique of f through h above for thermocouple TC2 (fig. 3).
- k.** Place leads from differential thermocouple (fig. 2) on base of TI near exit port.

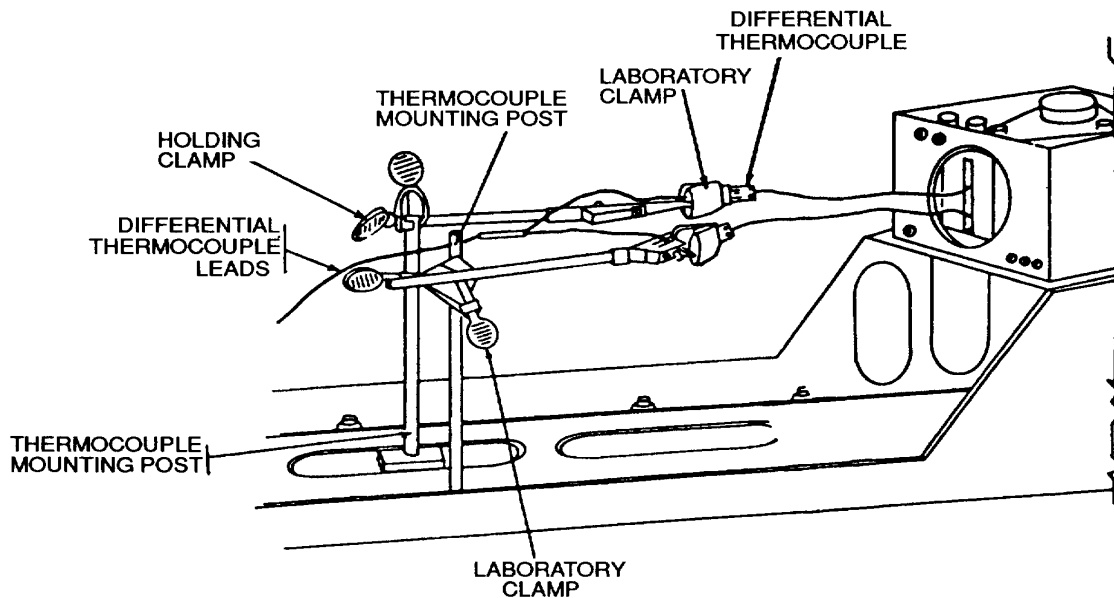

Figure 2. Equipment setup.

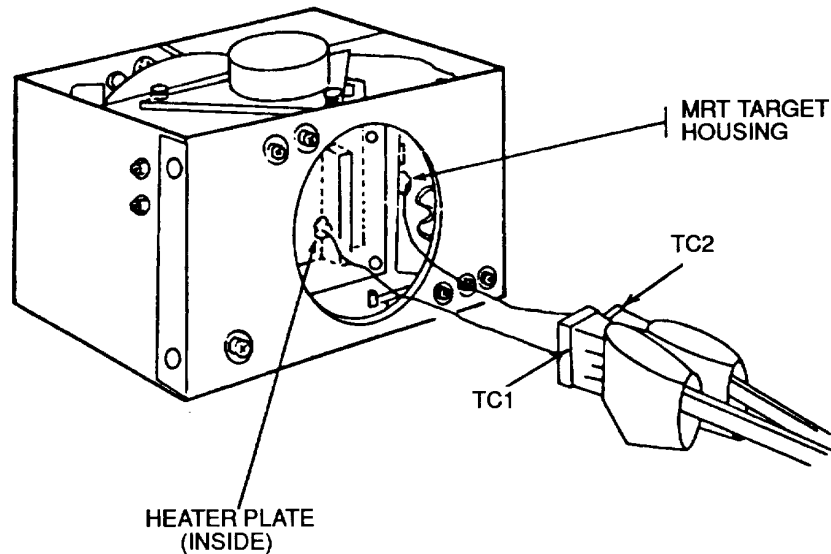

Figure 3. Temperature controller – heater plate.

- l.** Install shroud on TI.

NOTE

Verify that differential voltmeter operates properly in battery operate mode.

- m.** Pull leads through exit port and connect to differential voltmeter observing indicated polarity.

- n.** Open shroud access door (top) and remove 4 screws from top of cover plate of TI temperature controller and remove cover plate.

- o.** Place offset voltage pin adapters on pin J7 (black) and J9 (red) (fig. 1). Connect leads to proper pin adapter (black to black, red to red).

- p.** Draw leads through side access port of shroud and connect to digital voltmeter.

- q.** Connect temperature controller to 115 V ac power source.

NOTE

Ensure that power switch is in OFF position.

- r. Connect digital voltmeter to 115 V ac power source, turn power on, and allow 15 minutes to warm up.
- s. Set offset voltage (toggle) switch to **ALIGN** (fig. 1).
- t. Energize TI and observe indication on digital voltmeter.

NOTE

If this is the initial calibration, adjust temperature controller potentiometer R4 (fig. 1) for an indication of 4.30 ± 0.05 V dc on digital voltmeter.

NOTE

Deenergize TI immediately after performing **u** below.

- u. If necessary, adjust temperature controller potentiometer R4 (fig. 1) for digital voltmeter indication equal to previous offset voltage listed on TI offset voltage label (located on temperature controller) ± 0.05 V dc. Record indication as V_o .
- v. Set power switch to **OFF**.
- w. Set offset voltage switch to **ON**.
- x. Replace temperature controller cover plate but do not secure.
- y. Close top access hatch of shroud. Set power switch to **ON** and record start time and allow TI to warm up for 1 hour.

8. Calibration

a. Performance Check

NOTE

Short input connectors of differential voltmeter and adjust zero indication on the .0001 null range, if necessary. Remove short.

- (1) Observe and record indication on differential voltmeter in microvolts.
- (2) Using differential thermocouple set calibration data and indication on differential voltmeter, calculate the temperature difference indication and record as ΔT . If temperature difference is not between 4.05 °C and 4.95 °C, perform **b** below.

NOTE

Divide calibration factor, e.g., $40 \mu\text{V}/^\circ\text{C}$, into observed differential voltmeter indication. The result equals differential temperature.

b. Adjustments

- (1) Open access hatch on shroud and remove cover plate from TI temperature controller.

TB 9-5855-1890-35

(2) Set offset voltage switch to **ALIGN**.

(3) Adjust offset voltage potentiometer R4 (fig. 1) for an indication change of 0.1 V dc on digital voltmeter.

NOTE

If ΔT is less than 4.05 °C, decrease offset voltage; if ΔT is greater than 4.95 °C, increase offset voltage.

NOTE

As temperature indication nears in-tolerance condition, it may be necessary to adjust offset voltage in 0.05 V dc increments.

(4) Set offset voltage switch to **ON**.

(5) Replace temperature controller cover plate, close shroud access hatch, and allow 15 minutes for temperature stabilization.

(6) Observe and record indication on differential voltmeter.

(7) Using differential thermocouple set calibration data and indication on differential voltmeter, calculate the temperature difference indication.

(8) Repeat (1) through (7) above as required to produce a temperature difference indication between 4.35 °C and 4.65 °C.

(9) Set power switch to **OFF**, but do not disconnect test setup. Allow TI to cool for 15 minutes.

(10) Set voltage offset switch to **ALIGN**.

(11) When differential voltmeter indicates $0 \pm 10 \mu\text{V}$, set power switch to **ON** and immediately observe digital voltmeter indication and record as V_o (new).

(12) Set power switch to **OFF**.

(13) Set voltage offset switch to **ON**.

9. Final Procedure

a. Annotate value of V_o (new) on offset voltage label located on TI temperature controller (R).

NOTE

If TI has not required adjustment, record previous offset voltage as V_o (new).

- b.** Deenergize and disconnect all equipment and reinstall protective cover on TI.
- c.** Remove shroud and remove remaining test equipment. Replace temperature controller cover and tighten 4 screws. Disconnect and stow TI ac power cord.
- d.** Using cotton tip applicator soaked with paste removal solvent, clean thermally conductive paste from TI heater plate surface. Remove solvent residue using dry cotton tip applicator.

NOTE

If residue is severe a cotton tip applicator soaked in contact cleaner (Krylon #1333) may be used, followed by application of a dry cotton tip applicator.

- e.** Annotate and affix DA Label/Form in accordance with TB 750-25.

TB 9-5855-1890-35

By order of the Secretary of the Army:

CARL E. VUONO
General, United States Army
Chief of Staff

Official:

PATRICIA P. HICKERSON
Colonel, United States Army
The Adjutant General

Distribution:

To Be Distributed In Accordance With DA Form 12-34-E, Block No. 2084,
requirements for calibration procedure TB 9-5855-1890-35.

PIN NO: 060578-000